

PART LIST					
No.	QTY	PART NUMBER	PART NAME	MAT	DESCRIPTION
1	1	PUA0102	PUMP ASSY		JPR-V1000

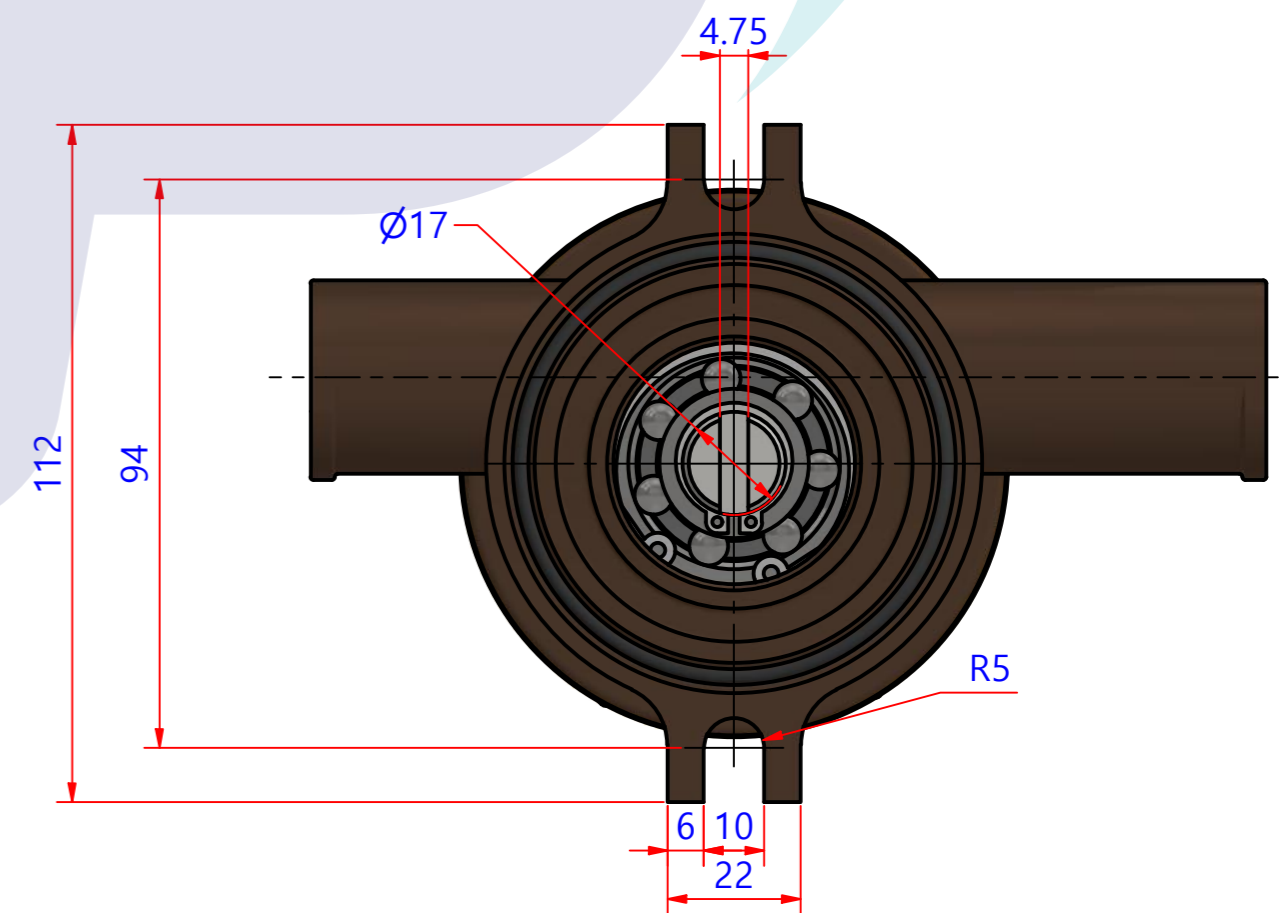
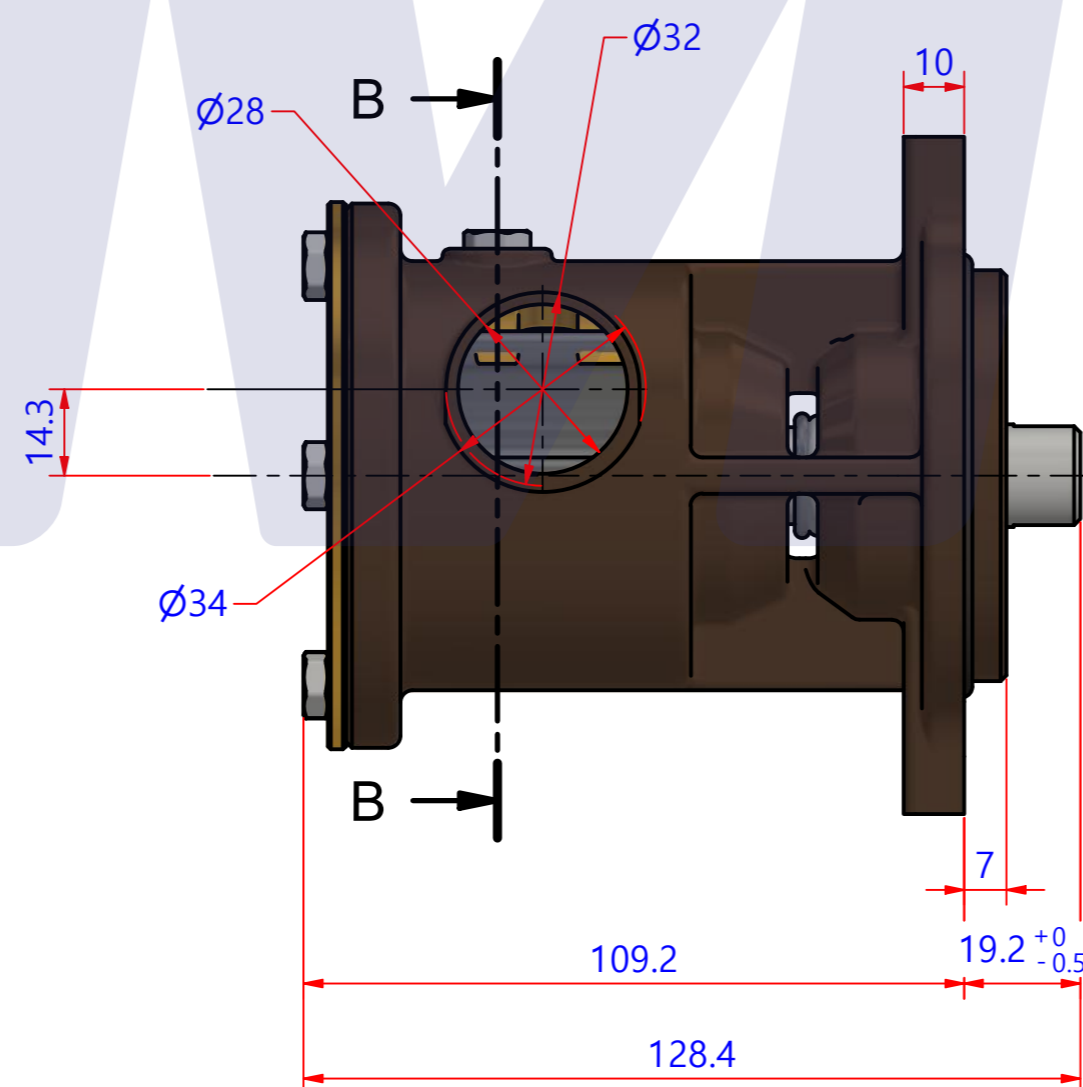
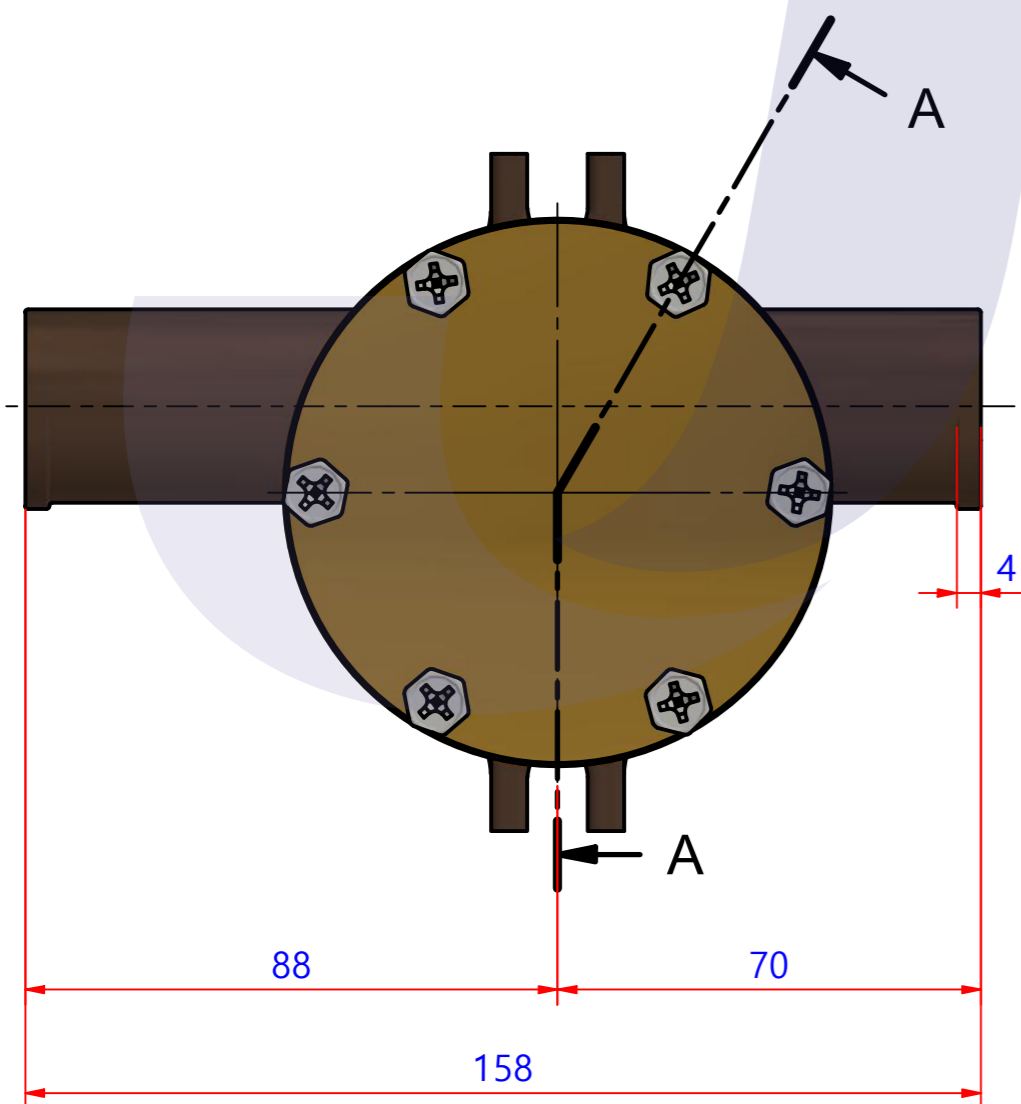
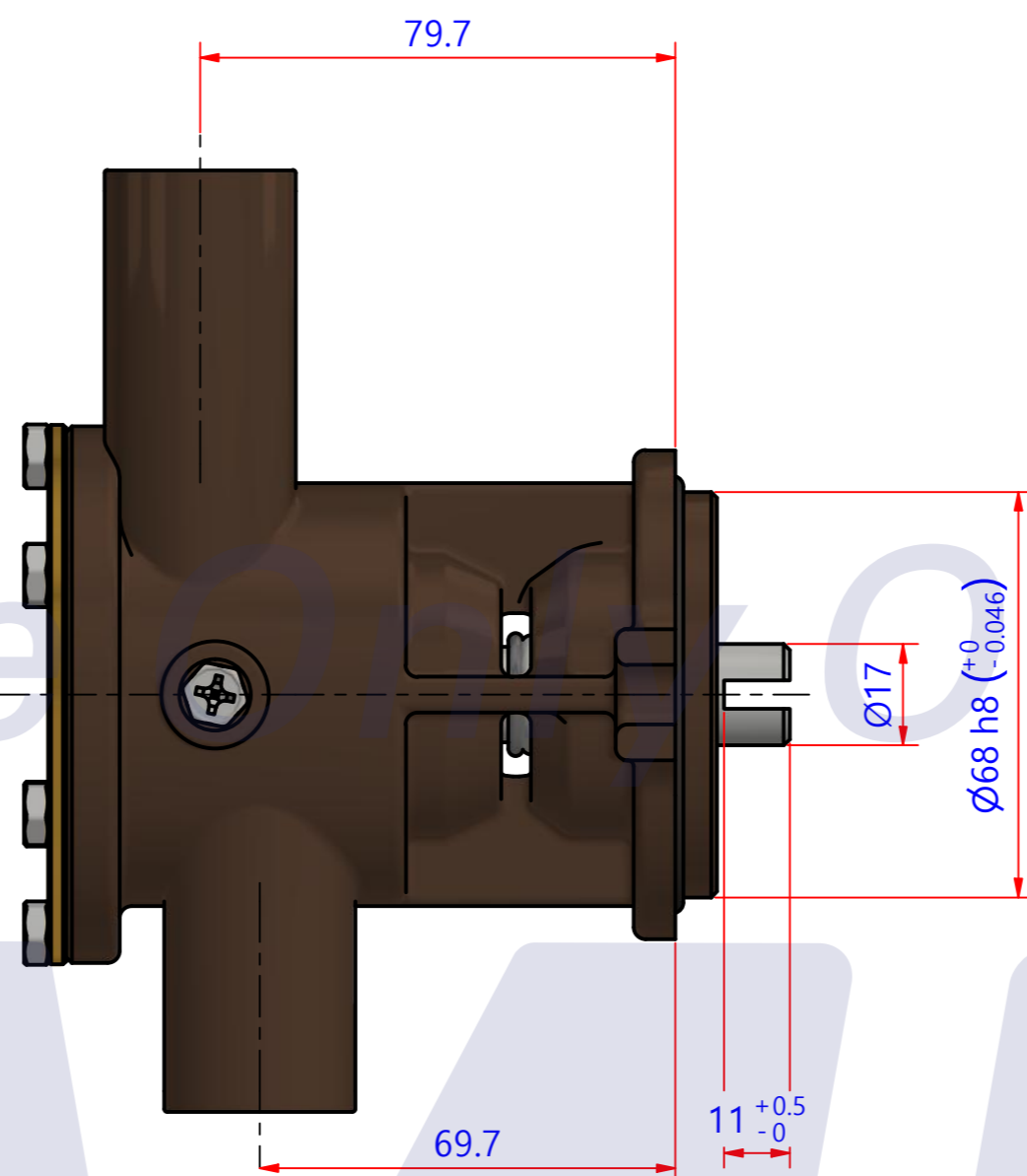
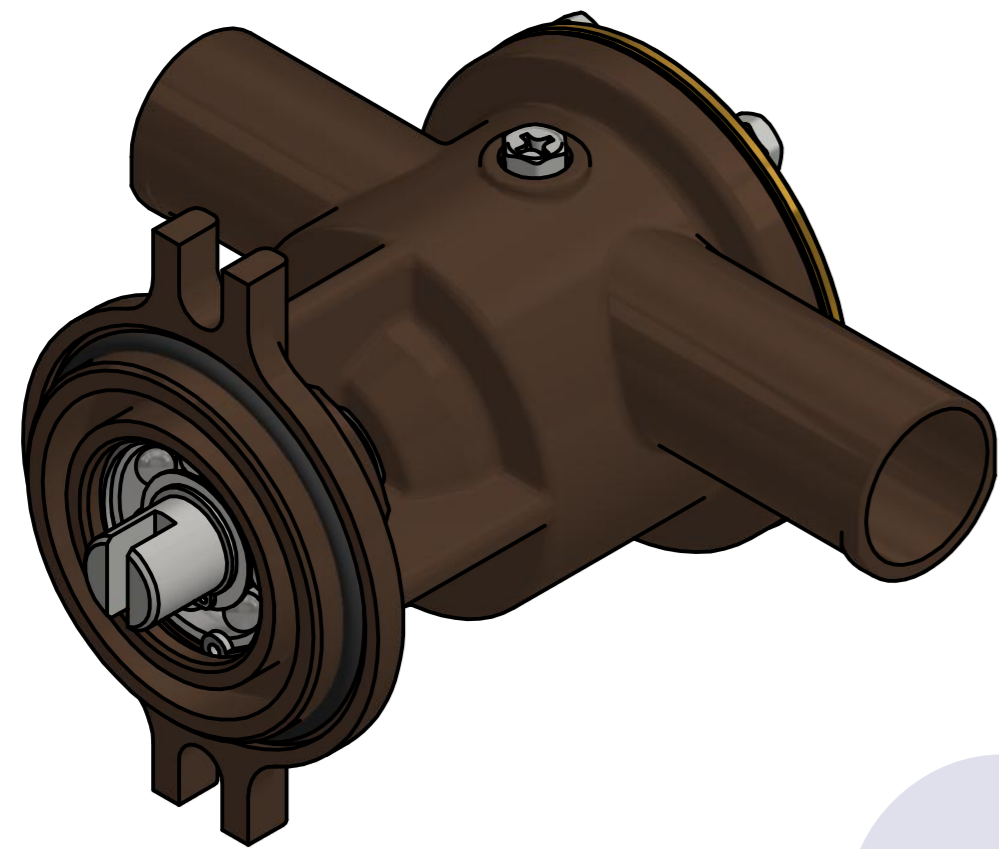

Drawing by	Checked by	Approved by - date	Model Name	Date	Scale
강 명진	Y.D. JEON		JPR-V1000	2014-05-23	1:1
			PUMP ASSY		
			PART NUMBER	PUA0102(0)	Sheet A2

품 번	PUA0102
품 명	JPR-V1000

A: MAJOR KIT B: MINOR KIT C: CAM SET D: M-SEAL SET E: IMPELLER KIT

No.	QTY	PART NUMBER	PART NAME	A (JSK0085)	B (JSM0030)	C (CAMSET000301)	D (MCSSET0008)	E (JIKJMP024)
1	1	BER0029	BEARING	X				
2	7	BOL0080	HEX BOLT	X	X	X (1)		
3	1	CAM000301	CAM	X	X	X		
4	1	COV000301	COVER	X	X			
5	1	GAK0009	FIBER GASKET	X	X	X		
6	1	7400-01	RUBBER IMPELLER	X	X			X
7	1	MCS0013	CERAMIC	X	X		X	
8	1	MCS0016	CARBON	X	X		X	
9	1	ORG0013	O-RING	X	X			X
10	1	ORG0044	O-RING	X				
11	1	ORG0096	O-RING					
12	1	PBC0175	PUMP CASING					
13	1	RET0044	RETAINER	X				
14	1	SHA0097	SHAFT	X				
15	1	SNP0002	SNAP-RING	X				
16	1	SNP0009	SNAP-RING	X				
17	1	SPC0019	SPACER	X	X			
18	1	WER0001	WEAR PLATE	X	X			

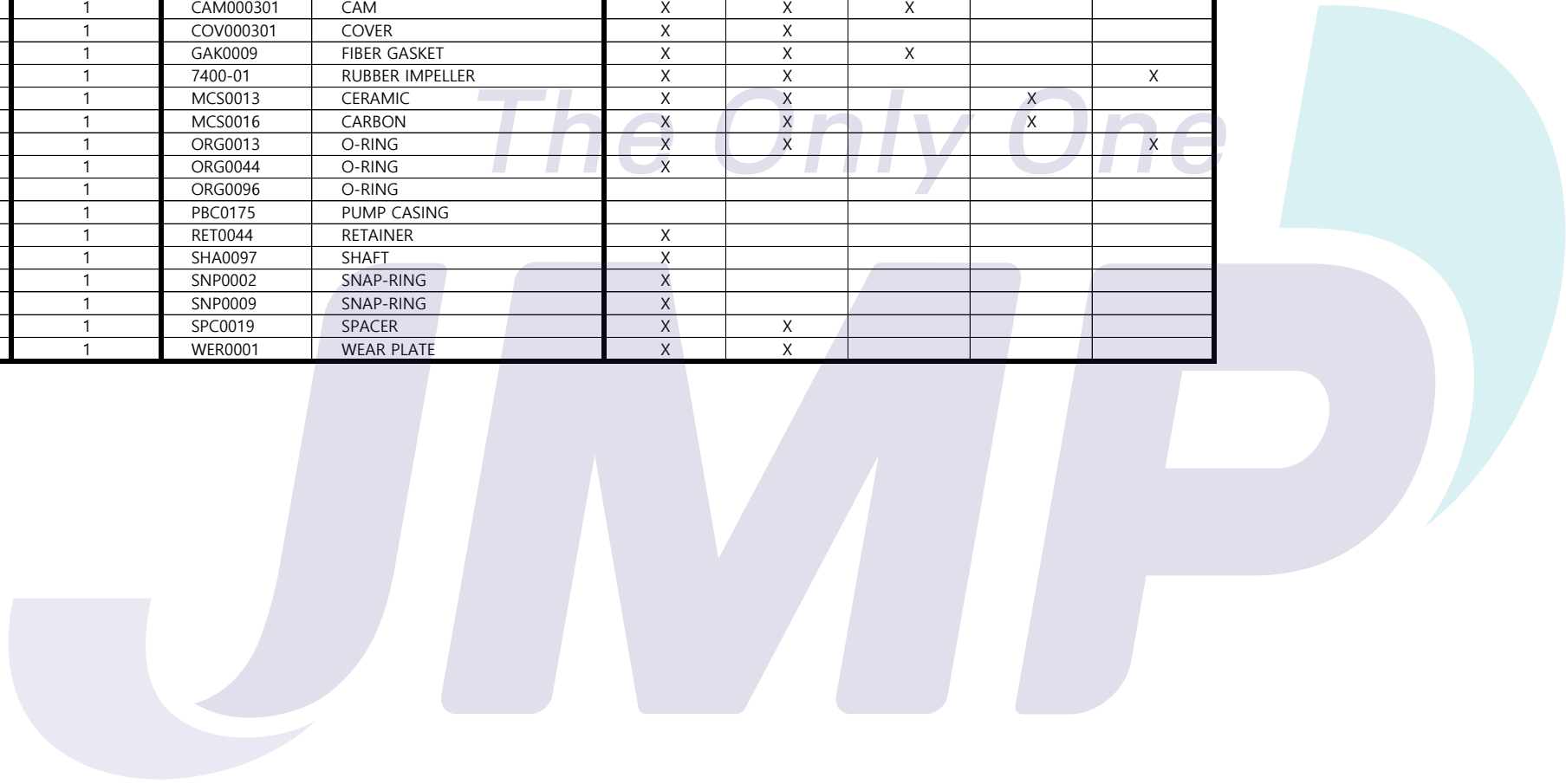

PART LIST					
No.	QTY	PART NUMBER	PART NAME	MAT	DESCRIPTION
1	1	PUA0102	PUMP ASSY		JPR-V1000

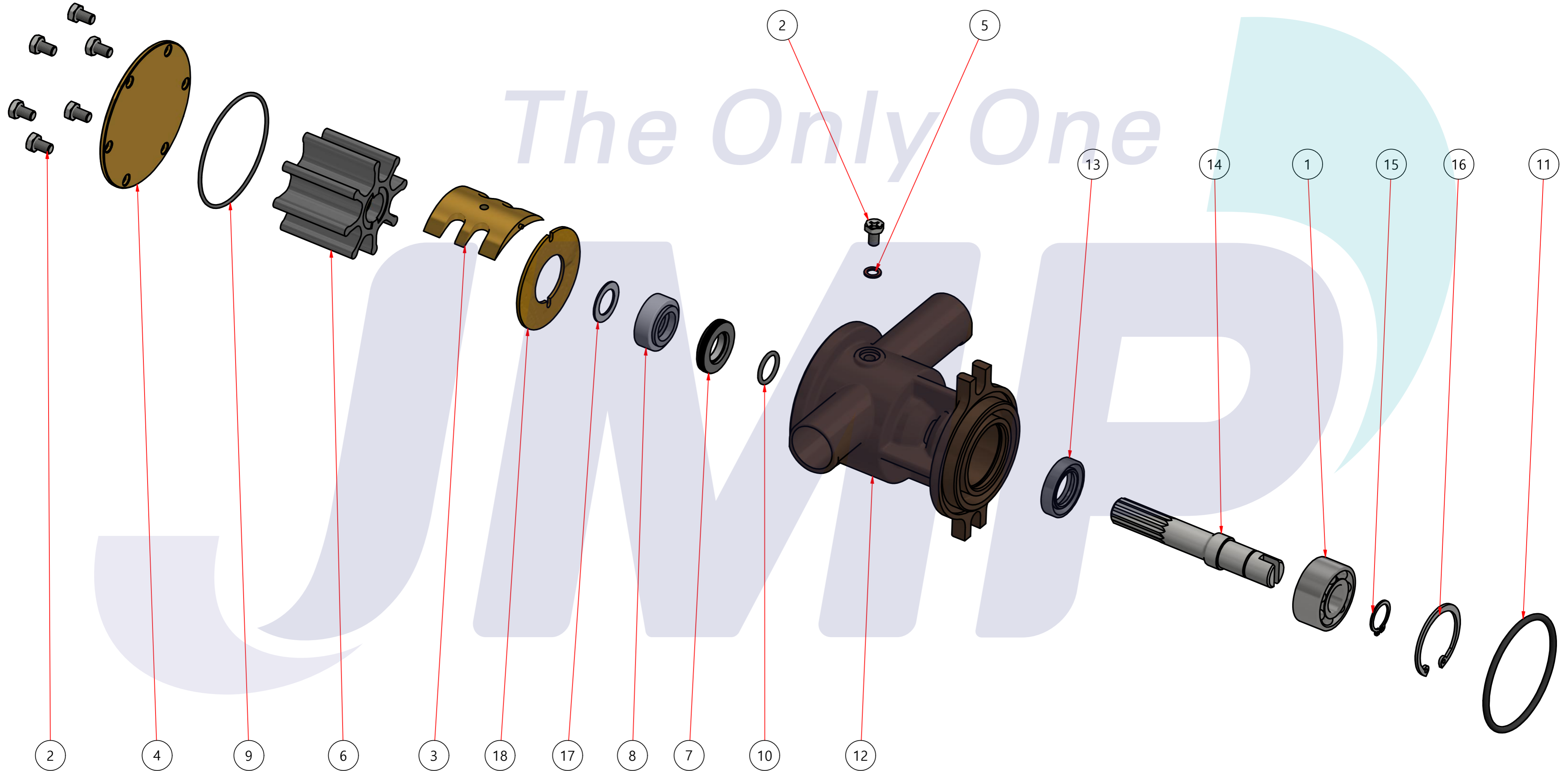

Drawing by	Checked by	Approved by - date	Model Name	Date	Scale
강 명진	Y.D. JEON		JPR-V1000	2014-05-26	1 : 1
			PUMP PART'S VIEW		
			PART NUMBER	Edition	Sheet
			PUA0102(0)	0	A2